

Regione Campania



costituita ex art.2 comma j, lettera a) della L.R. n. 16 del 28 novembre 2008
Sede: Via Lupoli, 27 - 80027 FRATTAMAGGIORE (NA)

Unità Operativa Complessa
Gestione Risorse Tecniche e Tecnologiche

Oggetto:

LAVORI DI REALIZZAZIONE DEL NUOVO BLOCCO OPERATORIO DEL PRESIDIO OSPEDALIERO "SANTA MARIA DELLE GRAZIE" -

Via Domitiana, loc.La Schiana - 80078 - Pozzuoli (NA)

PROGETTO ESECUTIVO

(artt.da 33 a 43, Parte II, Titolo II, Capo I, Sezione IV del D.P.R. 207/10)

EG	=	Elaborati Generali
AR	=	Opere Architettoniche
ST	=	Opere Strutturali
AS	=	Impianto Ascensore
IE	=	Impianti Elettrici e speciali
IM	=	Impianti a fluido
AP	=	Apparecchiature
TE	=	Documenti Tecnico Economici
PSC	=	Piano di Sicurezza e Coordinamento
IIS	=	Impianto idrico sanitario
IG	=	Impianto Gas Medicali

Cod.Elabor.

IE-08

descrizione:

SCHEMA A BLOCCHI

REV.

Scala

-

STATO DI FATTO E DI PROGETTO

REV.

Data

20 luglio 2018

DISTRIBUZIONE ELETTRICA IN CABINA

REV.

Progettista Architettonico e Strutturale

(Arch. Mauro Rullo)

Progettista Impianti Elettrici

Raggruppamento Temporaneo di Professionisti:

Mandatario:  **Innova Project srl**

(Ing. Salvatore D'Angelo)

Mandante: (Arch. Fabrizio Mirarchi)

Giovane Professionista: (Arch. Vincenzo Picone)

Progettista Impianti a Fluido



Direttore Tecnico: Prof. ing. Flavio Fucci

Il Direttore Generale

(Dr. Antonio D'Amore)

Il Direttore Sanitario

(Dr.ssa Virginia Scarfato)

Il Responsabile Unico del Procedimento

(Ing. Antonio Galdiero)

CABINA RICEZIONE

LOCALE CABINA DI TRASFORMAZIONE

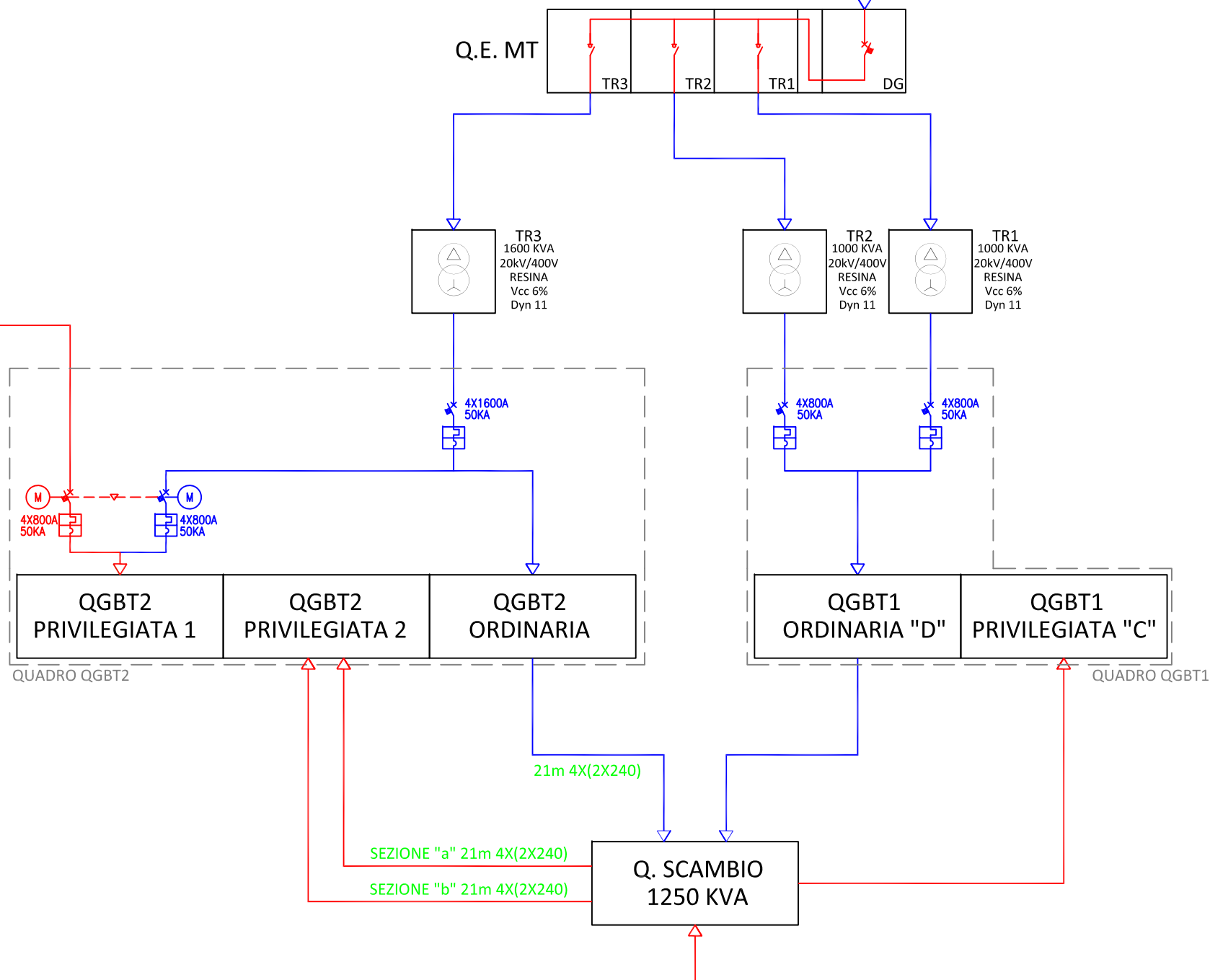
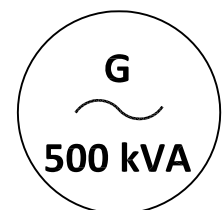

QGBT1 ORDINARIA "d"	
DISPONIBILI	
4X100A	FM C. OPERATORIO
4X160A	RISERVA
4X160A	RISERVA

QGBT1 PRIVILEGIATA "c"	
DISPONIBILI	
4X32A	ILLUM C. OPERATORIO
4X63A	F.M. C. OPERATORIO

QGBT2 ORDINARIA	
DISPONIBILI	
4X160A	C. OPERATORIO

QGBT2 PRIVILEGIATA2 SEZIONE "b"	
DISPONIBILI	
4X400A	G.F. C. OPERATORIO

QGBT2 PRIVILEGIATA1	
DISPONIBILI	
4X250A	C. OPERATORIO

STATO DI FATTO

CABINA RICEZIONE

LOCALE CABINA SECONDARIA

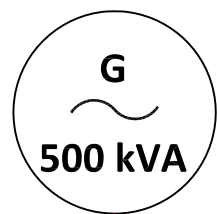

Q.E. MT

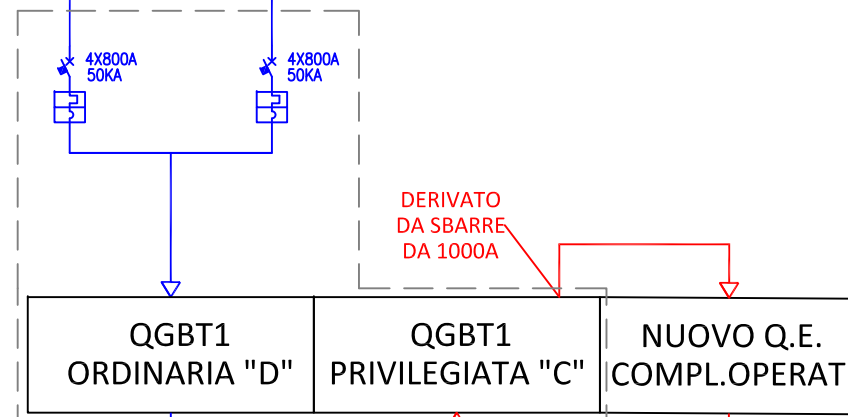
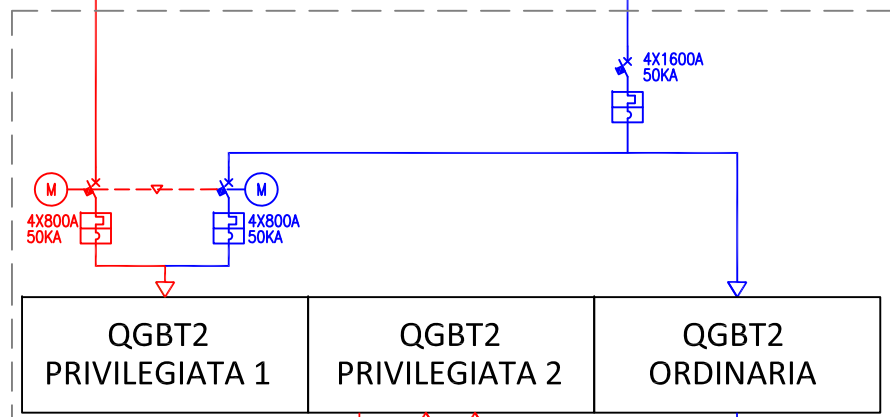
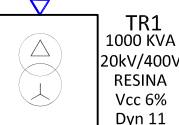
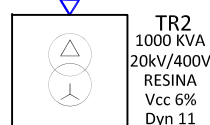
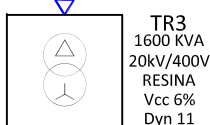
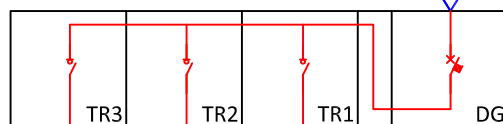

DERIVATO DA SBARRE DA 1000A

QUADRO NUOVO

QUADRO QGBT1

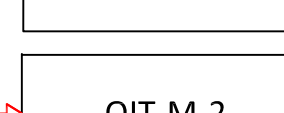
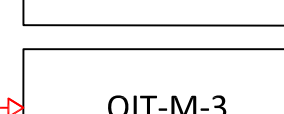
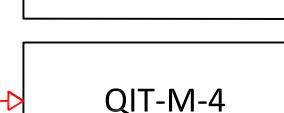
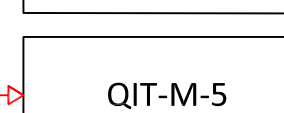
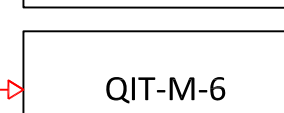
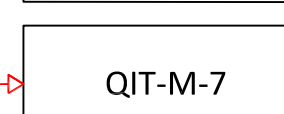
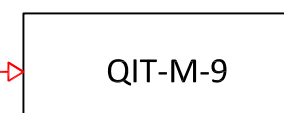
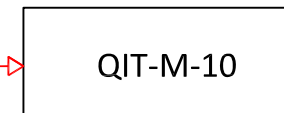
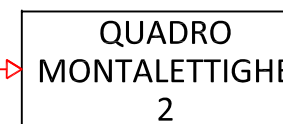
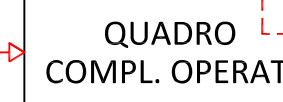
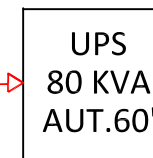
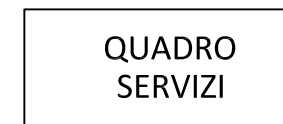
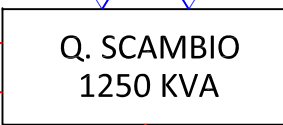

STATO DI PROGETTO

